

BH6.7(RK)

Parts Catalog

목 차

0. Chassis PART NO. W2

FIG 001 SUB FRAME	4
FIG 002 MAIN FRAME & VALVE	6
FIG 003 STABILIZER	8
FIG 004 LEVER	10
FIG 005 VALVE COVER	12
FIG 006 SWING BRACKET	14
FIG 007 BOOM COMP	16
FIG 008 DIPPER STICK & BUCKET COMP	18
FIG 009 SEAT ASSY	20
FIG 010 HOSE FITTING	22
FIG 011 LABEL GROUP	24
FIG 012 ACCESSORY	26

0. Chassis PART NO. W2

FIG 001 SUB FRAME	4
FIG 002 MAIN FRAME & VALVE	6
FIG 003 STABILIZER	8
FIG 004 LEVER	10
FIG 005 VALVE COVER	12
FIG 006 SWING BRACKET	14
FIG 007 BOOM COMP	16
FIG 008 DIPPER STICK & BUCKET COMP	18
FIG 009 SEAT ASSY	20
FIG 010 HOSE FITTING	22
FIG 011 LABEL GROUP	24
FIG 012 ACCESSORY	26

FIG 001

BH6.7(RK)

SUB FRAME

년/월
Year/Month

2022-03

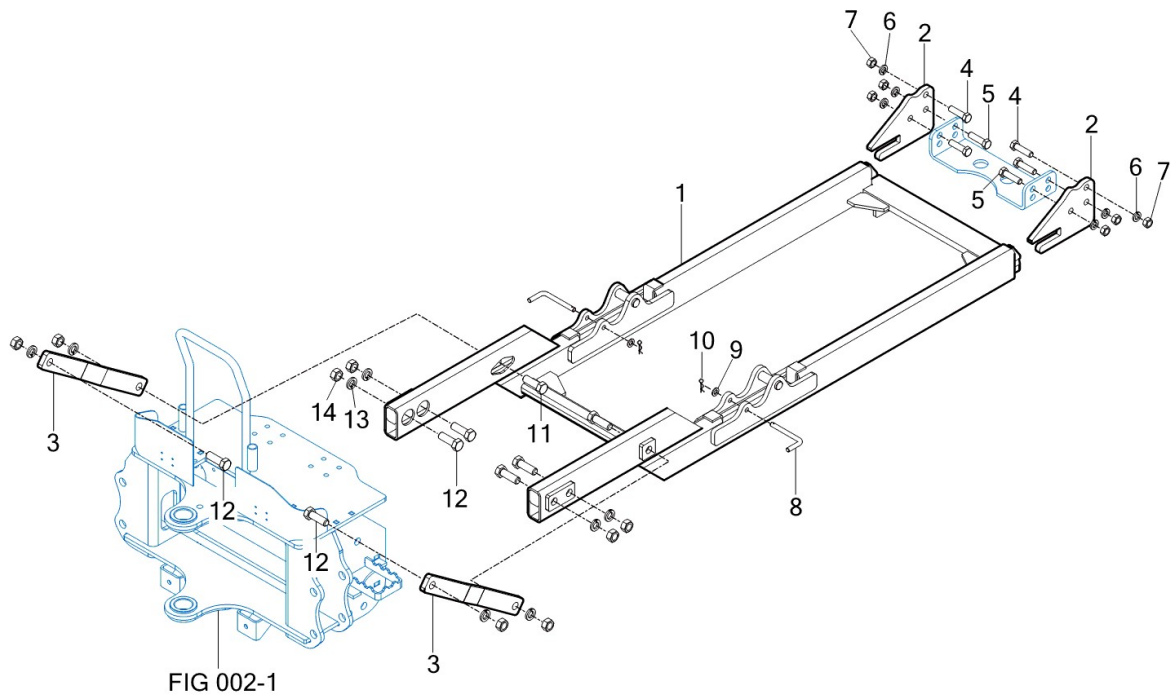

NOTE

FIG 002

BH6.7(RK)

MAIN FRAME & VALVE

년/월
Year/Month

2022-03

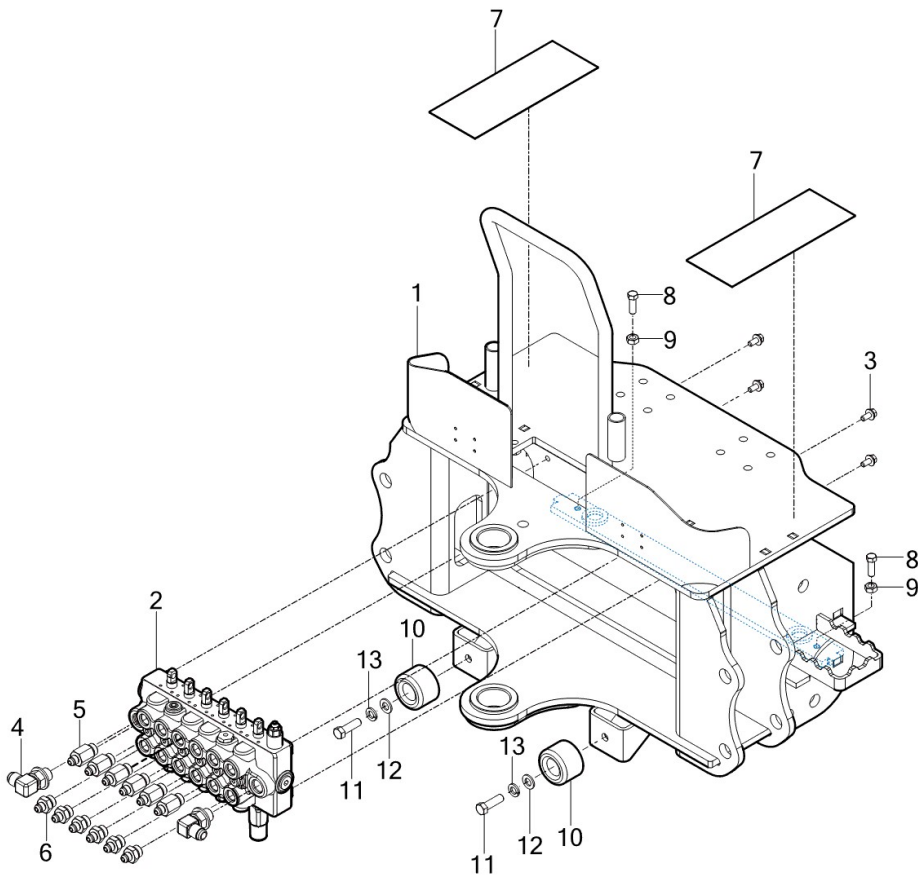

NOTE

FIG 003

BH6.7(RK)

STABILIZER

년/월
Year/Month

2022-03

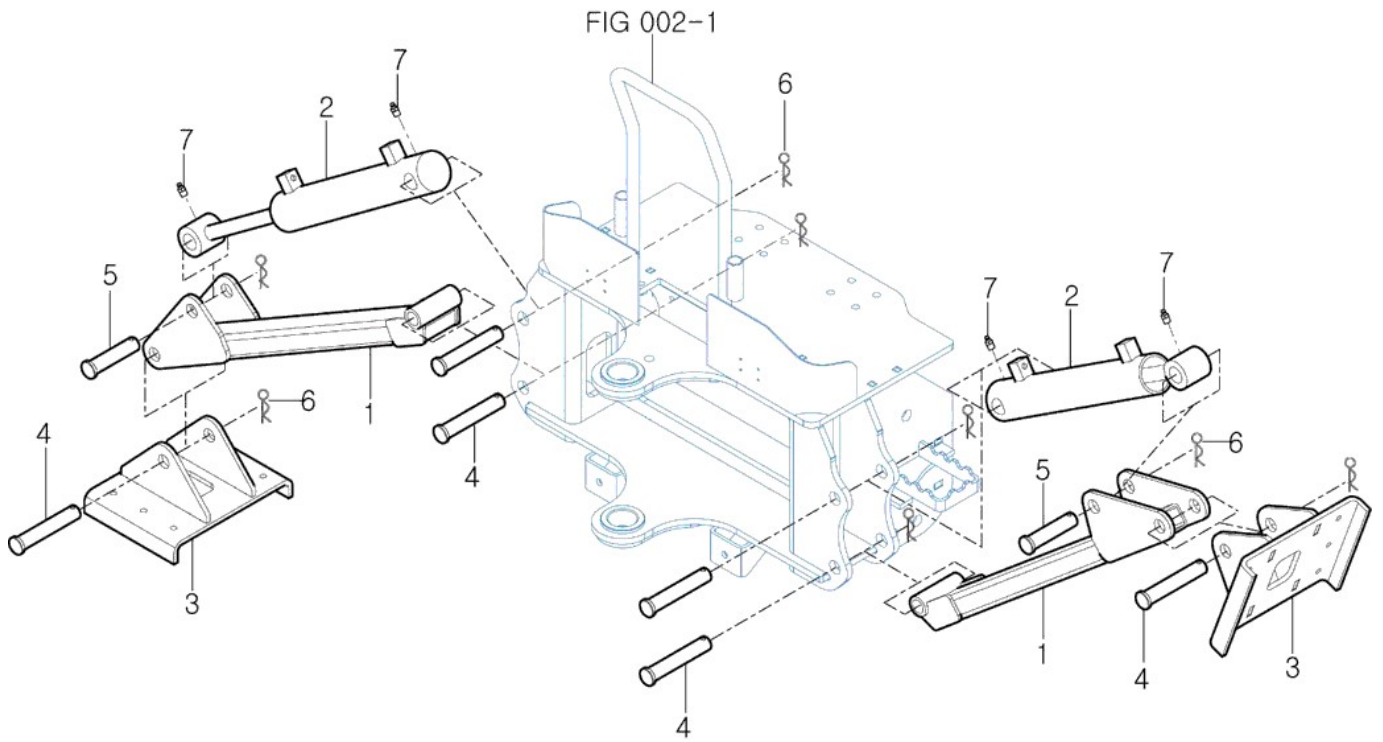

NOTE

FIG 004

BH6.7(RK)

LEVER

년/월
Year/Month

2022-03

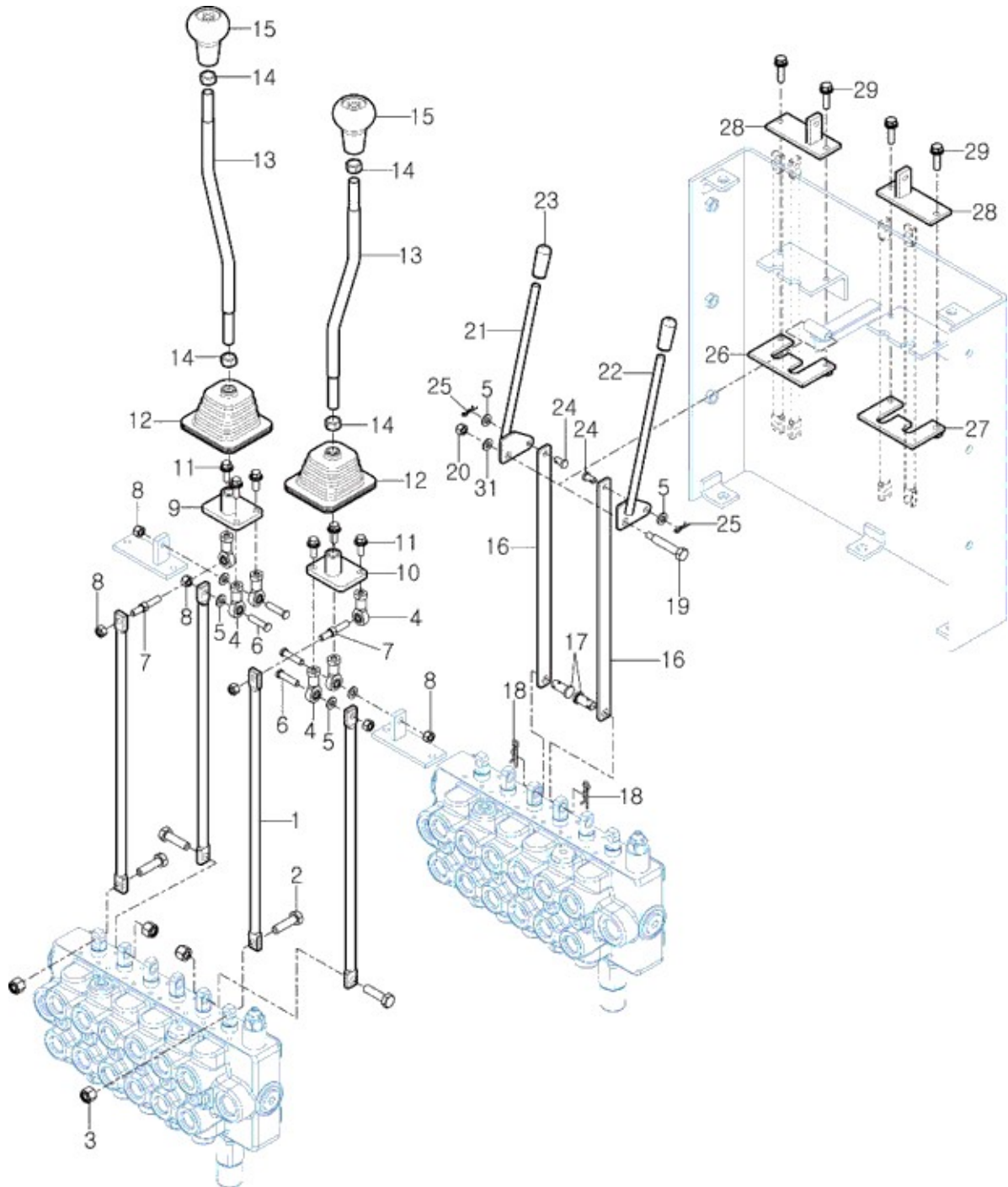

NOTE

FIG 005

BH6.7(RK)

VALVE COVER

년/월
Year/Month

2022-03

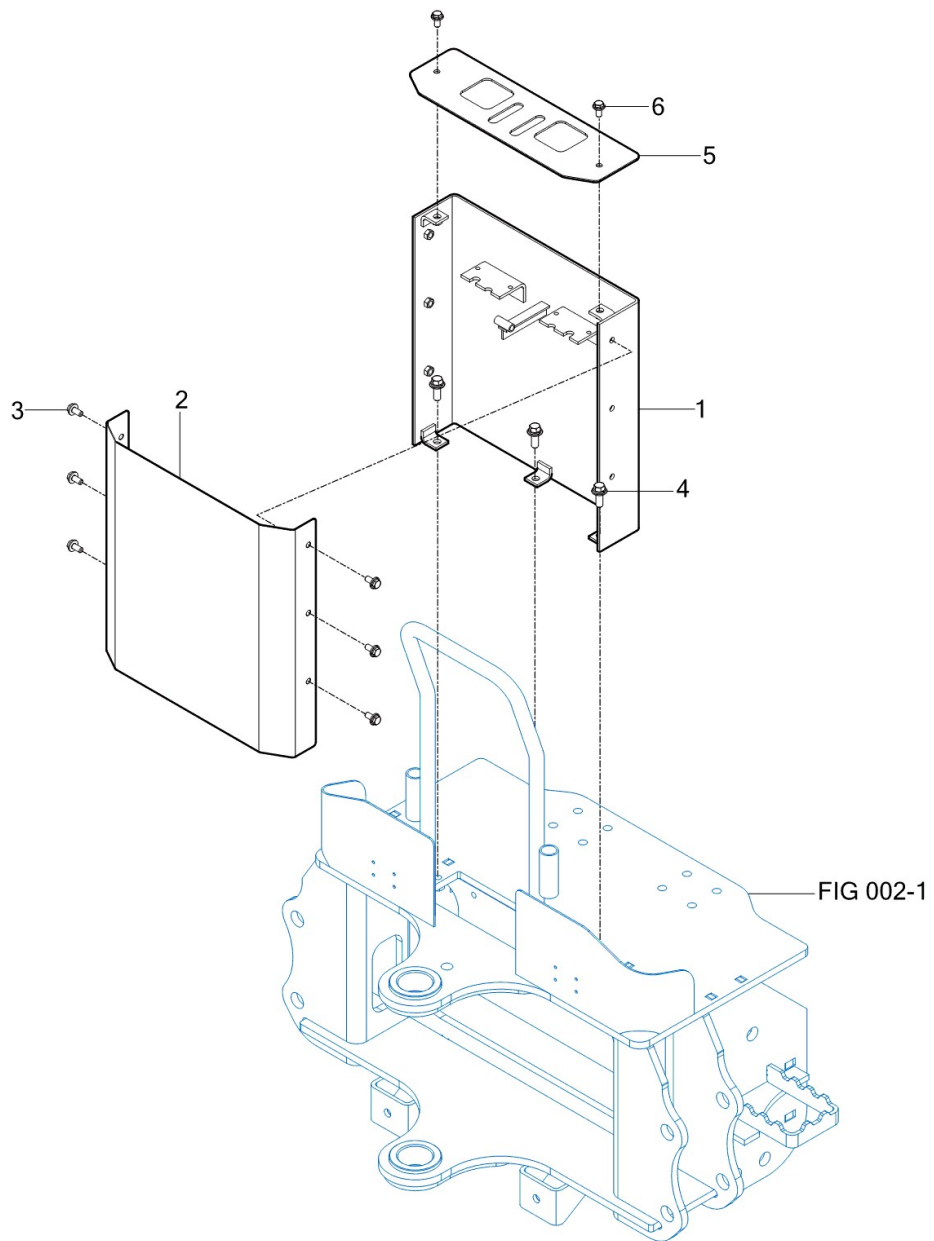

NOTE

FIG 006

BH6.7(RK)

SWING BRACKET

년/월
Year/Month

2022-03

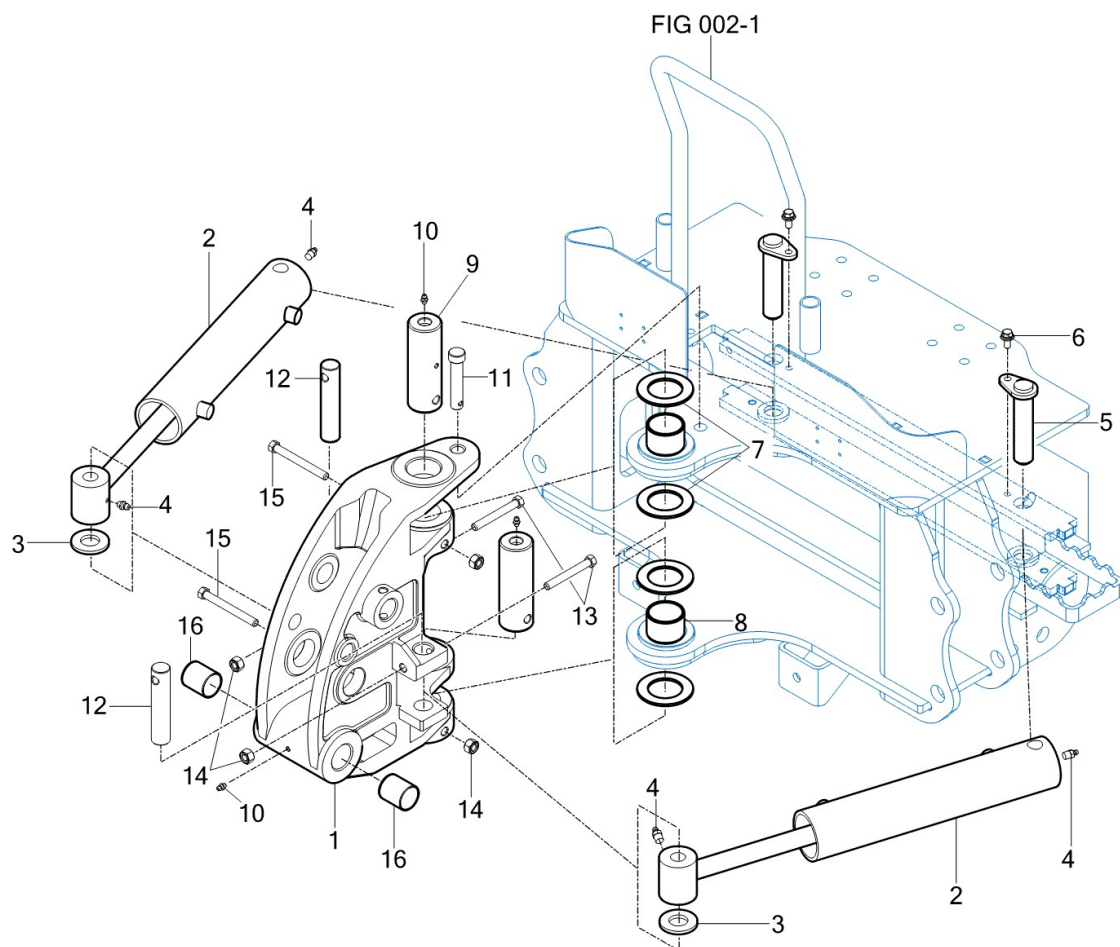

NOTE

FIG 007

BH6.7(RK)

BOOM COMP

년/월
Year/Month

2022-03

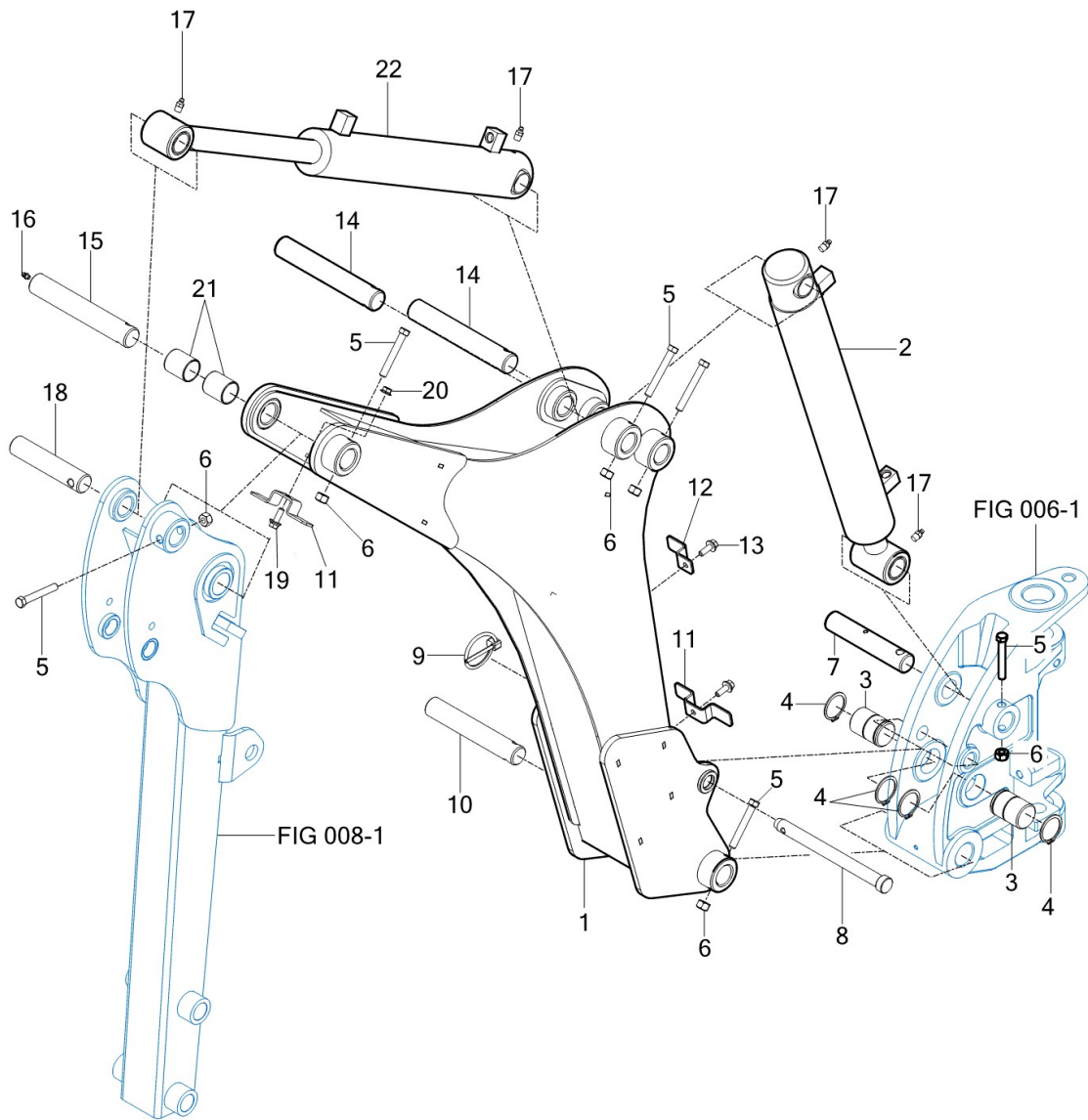

NOTE

FIG 008

DIPPER STICK & BUCKET COMP

년/월
Year/Month

2022-03

BH6.7(RK)

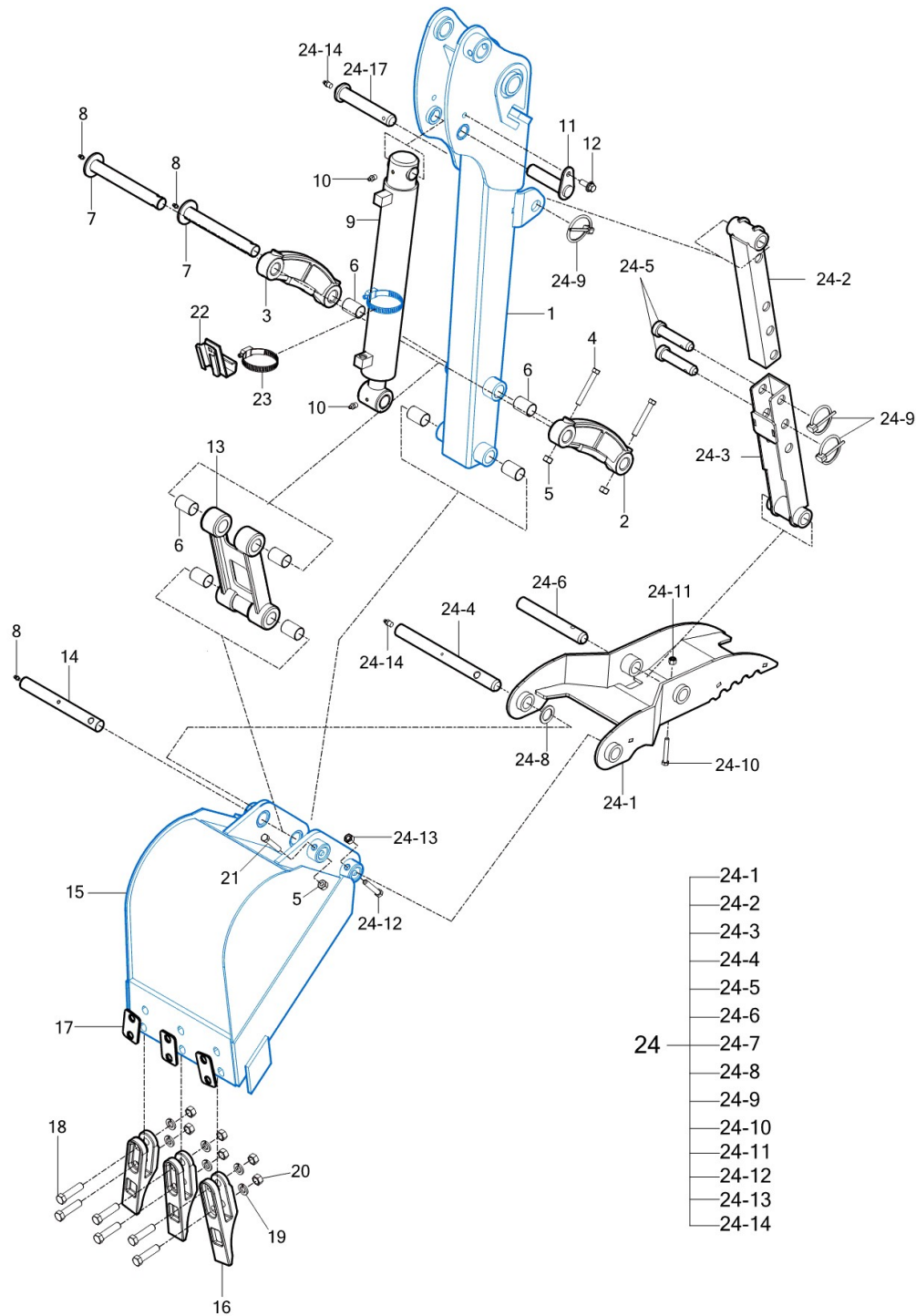

NOTE

FIG 009

BH6.7(RK)

SEAT ASSY

년/월
Year/Month

2022-03

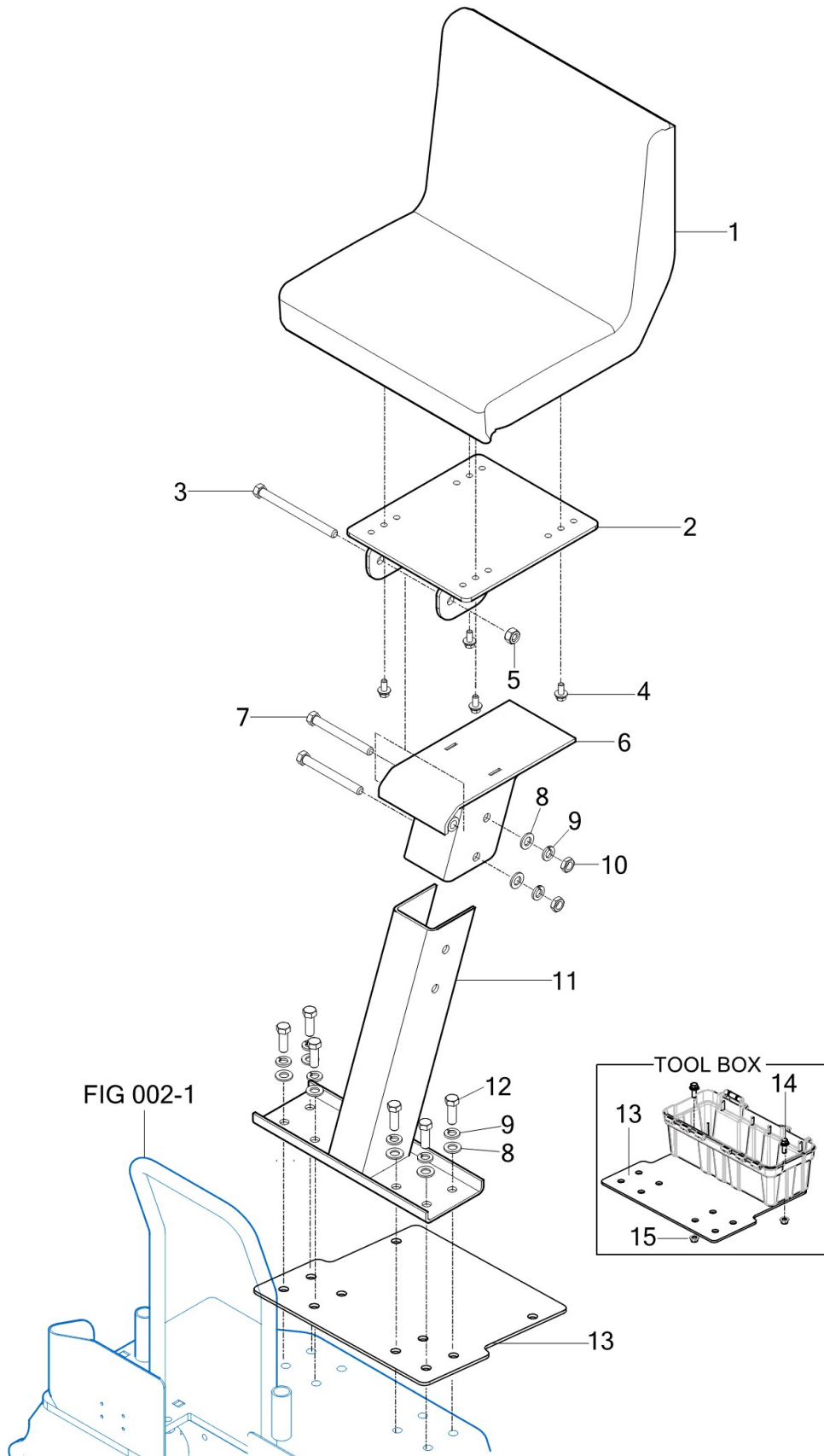

NOTE

FIG 010

HOSE FITTING

년/월
Year/Month

BH6.7(RK)

2022-03

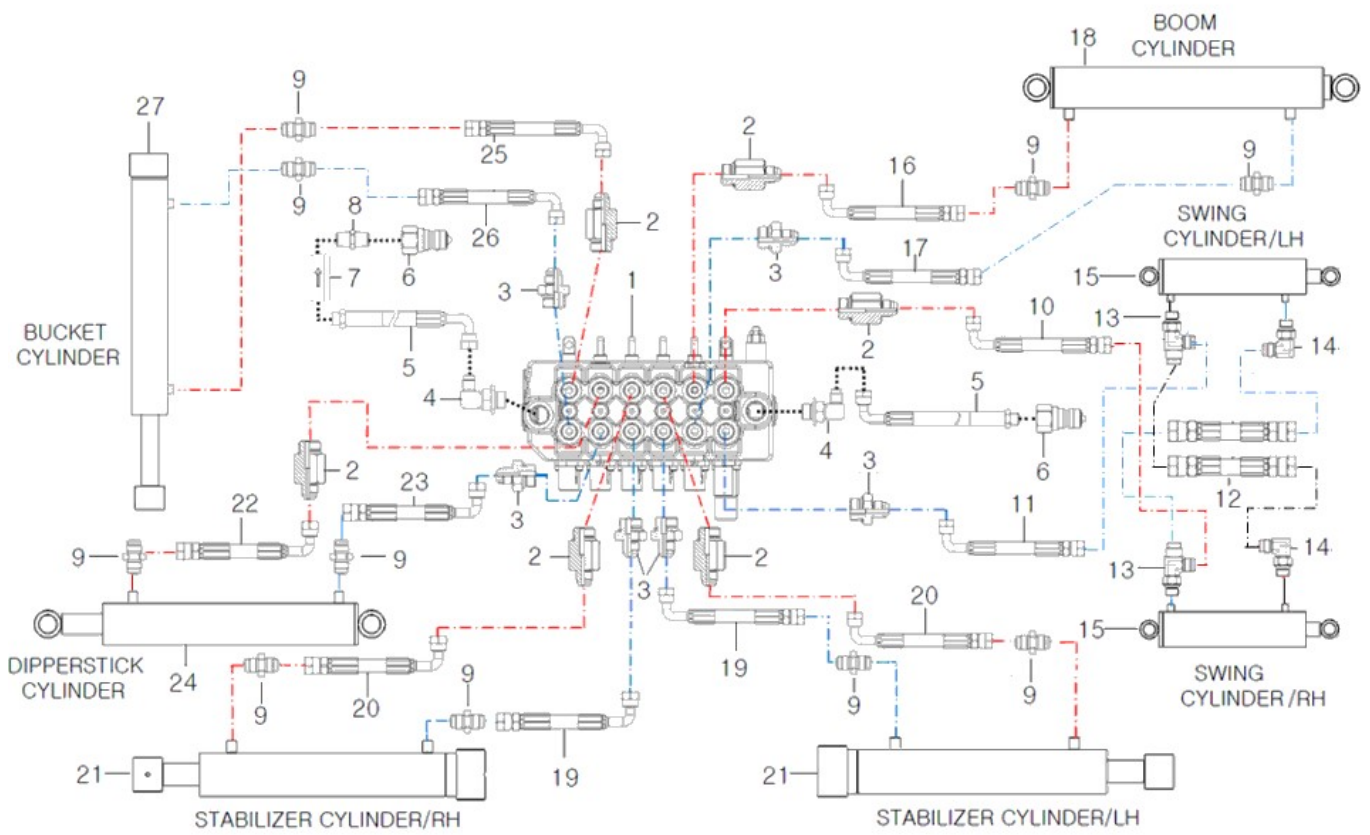

NOTE

FIG 011

LABEL GROUP

년/월
Year/Month

BH6.7(RK)

2022-03

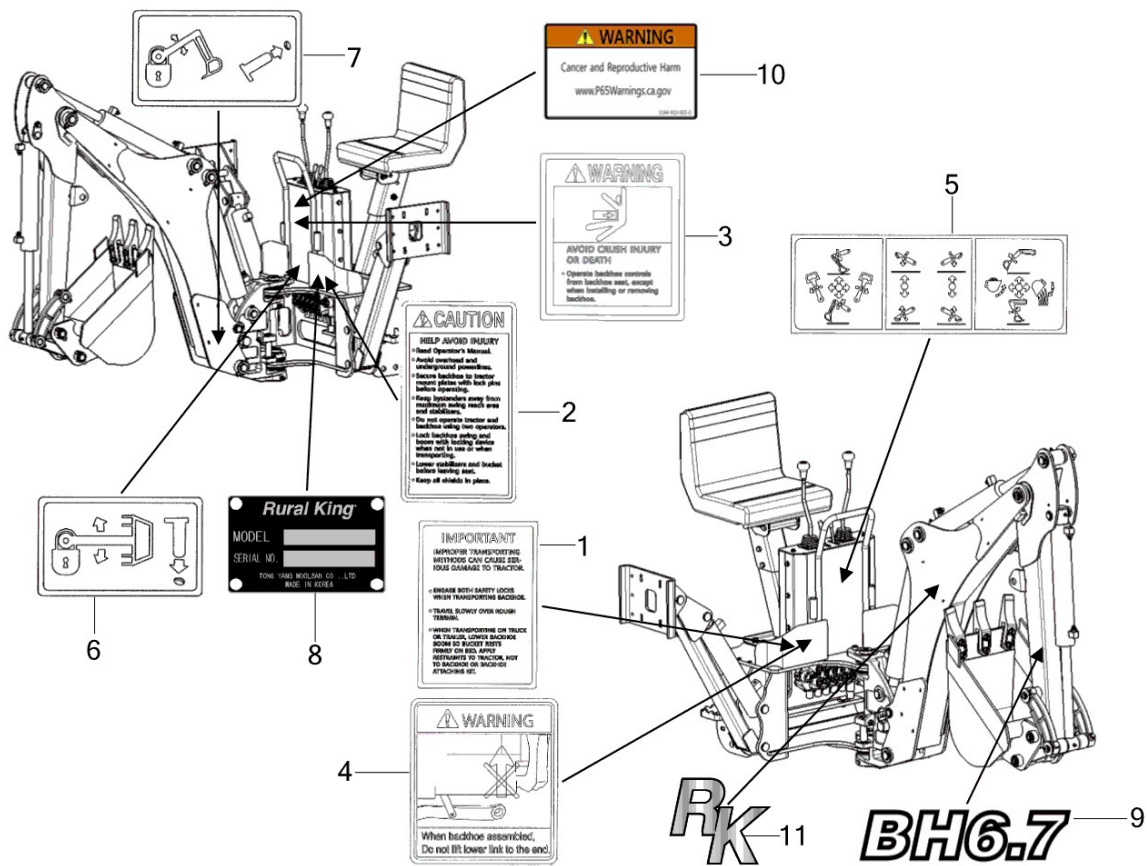

NOTE

FIG 012

BH6.7(RK)

ACCESSORY

년/월
Year/Month

2022-03

TOOL BOX PARTS

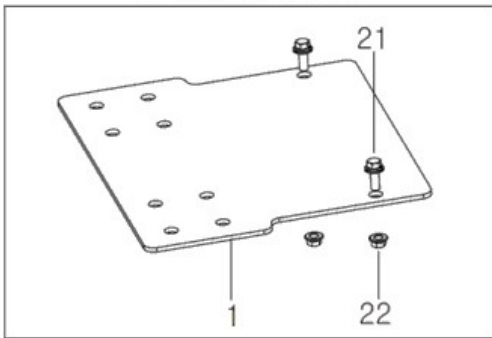

FIG 009 SEAT ASSY

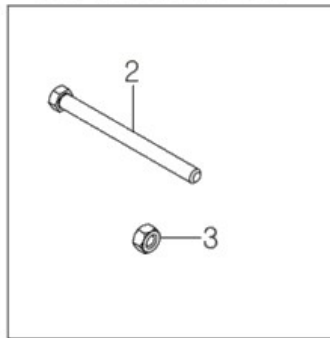

FIG 008 DIP&BUCKET COMP

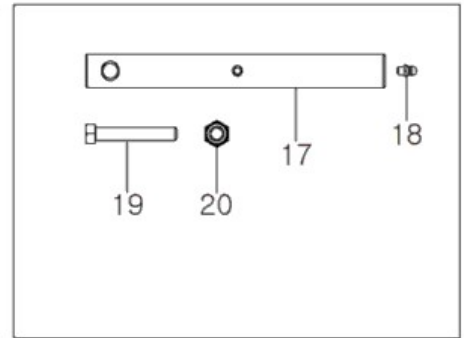
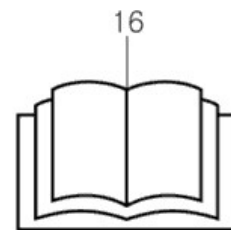
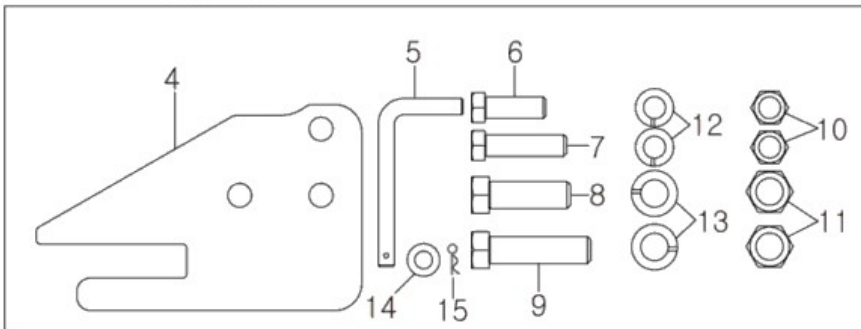

FIG 001 SUB FRAME



NOTE

